

**8K 48Gbps 4x4 HDMI  
Matrix  
USER MANUAL**

**BK-404**

*Follow us on Youtube and  
Facebook*



# Table of Contents

Introduction	04
Features	05
Package Contents	05
Specifications	06
Operation Controls and Functions	08
IR Remote	12
IR Cable Pin Assignment	13
EDID Management	14
Web GUI User Guide	16
RS-232 Control Command	30
Application Example	40

## Thank you for purchasing this product

Thank you for purchasing this product. For optimum performance and safety, please read these instructions carefully before connecting, operating or adjusting this product. Please keep this manual for future reference.

## Surge protection device recommended

This product contains sensitive electrical components that may be damaged by electrical spikes, surges, electric shock, lightning strikes, etc. Use of surge protection systems is highly recommended in order to protect and extend the service life of your equipment.

# Registration Page

Please Activate your warranty by registering our product through the link below  
- [www.orei.com/register](http://www.orei.com/register)

## Technical Support

### ***Need Help?***

Our experienced Technical Support Team is here for you to answer your questions, give technical advice or help troubleshoot your project to get you installed on time and on budget. Call, email or chat with us now.

### **OREI Live Technical Support Hours**

US team (US/Canada/Mexico): Monday-Friday, 9 a.m. - 6 p.m. Central Time

**Support Email** - [info@orei.com](mailto:info@orei.com) | **Support Number** - 877-290-5530

Or

### **Chat Live on [www.orei.com](http://www.orei.com)**

Send us an instant message now. Our Technical Support Team will respond momentarily. Available during live support hours.

# Introduction

The BK-404 Matrix is a 4 Input 4 Output HDMI Matrix that allows you to switch or split between different sources and displays at the same time with ease. It supports video resolutions up to 8K@60Hz 4:2:0 12bit and 4K@120Hz 4:4:4 12bit. The device features Optical and Analog audio outputs for audio extraction. The device can be easily controlled through the included remote, the front panel buttons, or through RS-232 & TCP/IP command control. It can also downscale 8K resolution to 4K or 8K/4K to 1080p on each output port. The device also features support for HDMI 2.1 features such as VRR, ALLM, QFT, QMS, and SBTM.

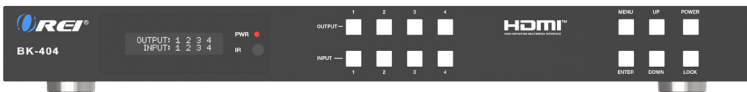

# Features & Package Contents

## Features

1. HDMI 2.1 & HDCP 2.3 compliant
2. 4 × HDMI inputs can be independently routed to 4 × HDMI outputs
3. Support 48Gbps video bandwidth and video resolution up to 8K@60Hz 4:2:0, 8K@30Hz 4:4:4 and 4K@120Hz 4:4:4.
4. HDR/10/10+, and Dolby Vision pass-through
5. Supports 8K->4K or 8K/4K->1080p downscaling for each output port
6. VRR, ALLM, QMS, QFT, SBTM are supported
7. Features Optical and balanced analog audio outputs for Audio Extraction
8. Advanced EDID management
9. Control via front panel buttons, IR remote, RS-232, and Web GUI

## Package Contents

1.	BK-404	1pcs
2.	24V/2.7A Locking Power Adapter	1pcs
3.	IR Remote	1pcs
4.	IR Wideband Receiver Cable (12V, 1.5m)	1pcs
5.	AC Power Cord (1.5m)	1pcs
6.	RS-232 Serial Cable (1.5m, male to female head)	1pcs
7.	5pin-3.81mm Phoenix Connector	4pcs
8.	Machine Screw (KM3*6)	8pcs
9.	Mounting Ear	2pcs
10.	User Manual	1pcs

# Specifications

Technical	
HDMI Compliance	HDMI 2.1
HDCP Compliance	HDCP 2.3
Video Bandwidth	48Gbps
Video Resolution	Up to 8K@60Hz 4:2:0, 8K@30Hz 4:4:4 and 4K@120Hz 4:4:4
Color Depth	8/10/12bit
Color Space	RGB_4:4:4, YCbCr_4:4:4, YCbCr_4:2:2, YCbCr_4:2:0
HDR Formats	HDR, HDR10, HDR10+, Dolby Vision, HLG
Audio Latency	No Latency
Video Latency	No Latency
HDMI Audio Formats	<p><b>HDMI IN/OUT:</b> LPCM, Dolby Digital/Plus/EX, Dolby True HD, Dolby Atmos, DTS, DTS-EX, DTS-96/24, DTS High Res, DTS-HD Master Audio, DSD</p> <p><b>AUDIO BREAKOUT:</b> Optical outputs: LPCM 2.0CH/Dolby/DTS 5.1CH Balanced Analog Audio Outputs: LPCM 2CH</p>
ESD Protection	IEC 61000-4-2: ±8kV (Air-gap discharge) & ±4kV (Contact discharge)
Connection	
Inputs	4 × HDMI INPUT [Type A, 19-pin female]
Outputs	4 × HDMI OUTPUT [Type A, 19-pin female] 4 × OPTICAL AUDIO [S/PDIF] 4 × L/R AUDIO [3.5mm Stereo Mini-jack]
Control	1 × TCP/IP [RJ45] 1 × RS-232 [D-Sub 9] 1 × IR EXT [3.5mm, Stereo Mini-jack]

# Specifications

<b>Mechanical</b>				
Housing	Metal Enclosure			
Color	Black			
Dimensions	440mm [L] × 203mm [W] × 44.5mm [H]			
Weight	2.65kg / 5.84lbs			
Power Supply	Input: AC 100-240V 50/60Hz, Output: DC 24V/2.7A (US/EU standard, CE/FCC/UL certified)			
Power Consumption	35W (Max)			
Operating Temperature	32 - 104°F / 0 - 40°C			
Storage Temperature	-4 - 140°F / -20 - 60°C			
Relative Humidity	20 - 90% RH (no-condensing)			
<b>Video Resolution</b>	<b>8K</b>	<b>4K60</b>	<b>4K30</b>	<b>1080P60</b>
<b>HDMI Cable Length</b> (HDMI IN / OUT)	3m/9.8ft (Ultra HDMI 2.1)	5m/16ft	10m/32ft	15m/50ft
The use of "Premium High Speed HDMI" cable is highly recommended.				

# Operation Controls and Functions

## Front Panel

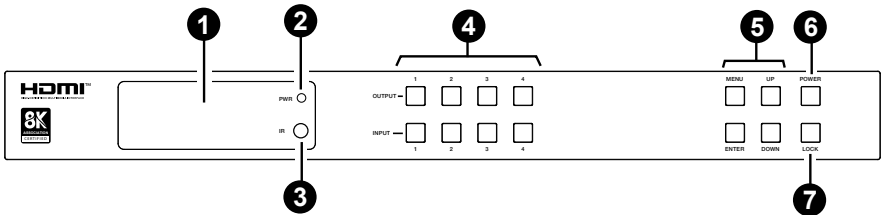

No.	Name	Function Description
1.	LCD screen	Displays the matrix switching status, input/output port, EDID, Baud rate, IP Address, etc.
2.	PWR LED	The LED lights up Green when the unit is turned on. It lights up Red when it is on standby.
3.	IR	IR signal receiver window. Receives the signal from the included IR remote.
4.	INPUT / OUTPUT buttons	You need to press an output button (1~4) first, and then press an input button (1~4) to select the corresponding input source for the output port.
5.	MENU / ENTER / UP / DOWN	<p>Take RESET, for example.</p> <p>① On the initial LCD display screen, press "MENU" button. There are OUTPUT/INPUT/EXTAUDIO/SETUP items to be selected.</p> <p>② Press the "UP/DOWN" button to select SETUP item.</p> <p>③ Press the "ENTER" button to enter into the next menu. There are LCD ONTIME/BAUDRATE/IP INFO/REBOOT/RESET items to be selected.</p> <p>④ Press the "UP/DOWN" button to select RESET item.</p> <p>⑤ Press the "ENTER" button to confirm reset. It will prompt: RESET SUCCESS!</p> <p>Note: Pressing the "MENU" button will return to the previous menu.</p>
6.	POWER button	Long press the POWER button for 1 second to enter the standby mode, then short press it to wake up the device.
7.	LOCK button	Short press the LOCK button to lock the front panel buttons (Except the power button); Press it again to unlock.



# Operation Controls and Functions

## Rear Panel

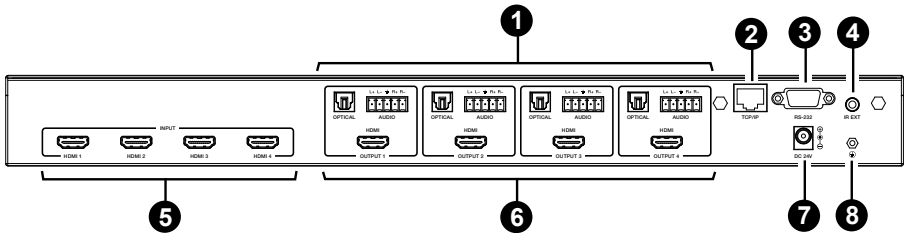

No.	Name	Function Description
1.	AUDIO OUT (1~4)	OPTICAL: Optical audio output port, connected to an audio output device such as audio amplifier. L/R AUDIO: Analog audio output port, supporting balanced/unbalanced audio output, with a maximum support of 2Vrms. Balanced connection method: L+, L-, $\frac{L}{2}$ , R+, R Unbalanced connection method: L+, $\frac{L}{2}$ , R+
2.	TCP/IP	TCP/IP control port, connected to PC or router with an RJ45 cable for control through Software or WebGUI.
3.	RS-232 port	Connects to a PC or control system by D-Sub 9-pin cable to transmit RS-232 command.
4.	IR EXT	If the IR receiver window of the unit is blocked or the unit is installed in a closed area out of infrared line of sight, the IR receiver cable can be inserted to the "IR EXT" port to receive the IR remote signal.
5.	HDMI INPUT ports (1~4)	HDMI input ports: Connected to a source device such as an 8K computer, DVD or set-top box.
6.	HDMI OUTPUT ports (1~4)	HDMI output ports: Connected to a display device such as a TV or monitor.
7.	DC 24V	Connect the included 24V/2.7A power supply.
8.	GND	Connect the housing to the ground.

### Note:

1. You can restore the factory settings via the front panel, WebGUI or RS-232 command.
2. Power cut memory function is available except for standby status.
3. The RS-232 and WebGUI will be available few minutes after the unit is powered on.

# Operation Controls and Functions

## LCD Display Navigation

The buttons on the the front panel are used for LCD display navigation, including INPUT(1~4), OUTPUT(1~4), MENU, ENTER, UP, DOWN.

Menu contents are as follows:

Level 1	Level 2	Level 3	Level 4	
OUTPUT	SCALER	OUT1/OUT2/OUT3/OUT4	BYPASS	
			8K to 4K	
			8K/4K to 1080P	
			AUTO	
	HDR	OUT1/OUT2/OUT3/OUT4	BYPASS	
			HDR to SDR	
	ARC	OUT1/OUT2/OUT3/OUT4	ON	
			OFF	
	STREAM	OUT1/OUT2/OUT3/OUT4	ENABLE	
			DISABLE	
	INPUT	EDID	IN1/IN2/IN3/IN4	z=1. 1080P, 2.0CH, z=2. 1080P, 5.1CH, z=3. 1080P, 7.1CH, z=4. 4K30, 2.0CH, z=5. 4K30, 5.1CH, z=6. 4K30, 7.1CH, z=7. 4K60(420), 2.0CH, z=8. 4K60(420), 5.1CH, z=9. 4K60(420), 7.1CH, z=10. 4K60(444), 2.0CH, z=11. 4K60(444), 5.1CH, z=12. 4K60(444), 7.1CH, z=13. 1080P_HDR, 2.0CH, z=14. 1080P_HDR, 5.1CH, z=15. 1080P_HDR, 7.1CH, z=16. 4K30_HDR, 2.0CH, z=17. 4K30_HDR, 5.1CH, z=18. 4K30_HDR, 7.1CH, z=19. 4K60(420)_HDR, 2.0CH, z=20. 4K60(420)_HDR, 5.1CH, z=21. 4K60(420)_HDR, 7.1CH z=22. 4K60(444)_HDR, 2.0CH, z=23. 4K60(444)_HDR, 5.1CH, z=24. 4K60(444)_HDR, 7.1CH, z=25. 4K120(420)_HDR, 2.0CH, z=26. 4K120(420)_HDR, 5.1CH, z=27. 4K120(420)_HDR, 7.1CH z=28. 4K120(444)_HDR, 2.0CH, (to be continued)

# Operation Controls and Functions

Level 1	Level 2	Level 3	Level 4	
INPUT	EDID	IN1/IN2/IN3/IN4	z=29. 4K120(444)_HDR, 5.1CH, z=30. 4K120(444)_HDR, 7.1CH, z=31. FRL10G_8K_HDR, 2.0CH, z=32. FRL10G_8K_HDR, 5.1CH, z=33. FRL10G_8K_HDR, 7.1CH, z=34. FRL12G_8K_HDR, 2.0CH, z=35. FRL12G_8K_HDR, 5.1CH, z=36. FRL12G_8K_HDR, 7.1CH, z=37. user1_EDID, z=38. user2_EDID, z=39. user3_EDID, z=40. copy out1 z=41. copy out2 z=42. copy out3 z=43. copy out4	
EXTAUDIO	OUT	OUT1/OUT2/OUT3/ OUT4	ENABLE DISABLE	
	MODE	BIND to INPUT	/	
		BIND to OUTPUT	/	
		AUDIO MATRIX	/	
MATRIX	OUT1/OUT2/OUT3/ OUT4	INPUT1 INPUT2 INPUT3 INPUT4 OUTPUT1 ARC OUTPUT2 ARC OUTPUT3 ARC OUTPUT4 ARC		
SETUP	LCD ONTIME	OFF ALWAYS ON 15 SECONDS 30 SECONDS 60 SECONDS	/	
	BAUDRATE	4800 9600 19200 38400 57600 115200	/	
		IP INFO	DHCP: ON/OFF 192.168.0.100	/
		REBOOT	SUCCESS!	/
		RESET	SUCCESS!	/

# IR Remote

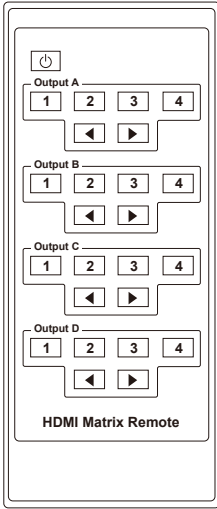

Power on the Matrix or set it to standby mode.

### Output A:

Press 1\2\3\4 button to select the input source for HDMI OUTPUT 1.

### Output B:

Press 1\2\3\4 button to select the input source for HDMI OUTPUT 2.

### Output C:

Press 1\2\3\4 button to select the input source for HDMI OUTPUT 3.

### Output D:

Press 1\2\3\4 button to select the input source for HDMI OUTPUT 4.

◀ ▶: Select the last or next signal input source.

You can select input and output channel using the IR remote. There are two ways to receive the IR remote signal.

**The first way:** The IR window accepts the IR remote signal. Using the IR remote, the furthest distance is 8 meters when the IR remote is directly faced to the matrix, and 5 meters when the using angle is  $\pm 45^\circ$ . The diagram is shown below:

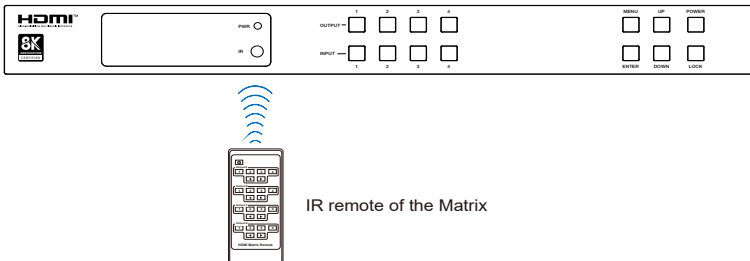

IR remote of the Matrix

# IR Remote & IR Cable Pin Assignment

**The second way:** If the IR receiver window of the Matrix is blocked or the Matrix is installed in a closed area out of infrared line of sight, the IR receiver cable can be inserted to the "IR EXT" port to receive the IR remote signal. The furthest distance of using the IR remote is 5 meters when the IR remote is directly faced to the IR receiver head, and 3 meters when the using angle is  $\pm 45^\circ$ . The diagram is shown below.

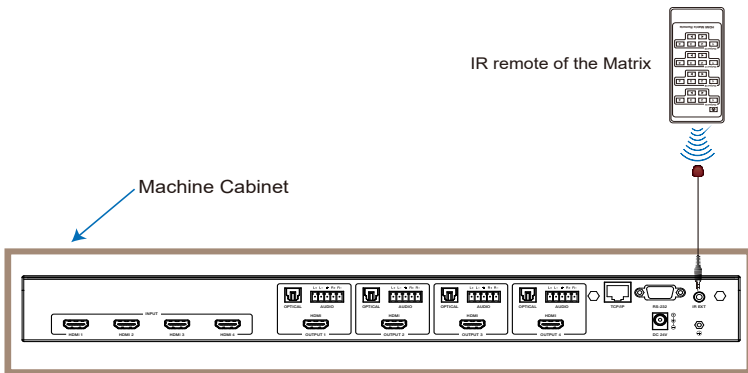

## IR Cable Pin Assignment



IR RECEIVER

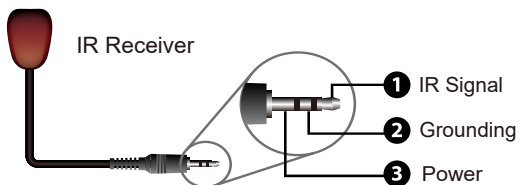

# EDID Management

This Matrix has 36 factory defined EDID settings, 3 user-defined EDID modes and 4 copy EDID modes. You can select defined EDID mode or copy EDID mode to input port through front panel buttons, RS-232 control or Web GUI.

**On-panel button operation:** On the initial LCD display screen, press "MENU" button to enter the first level menu, press "UP/DOWN" button to select INPUT, and then press the "ENTER" button. Now the EDID item appears. Press the "ENTER" button, and then press "UP/DOWN" button to select the EDID mode you need. Then press "ENTER" button to confirm this operation.

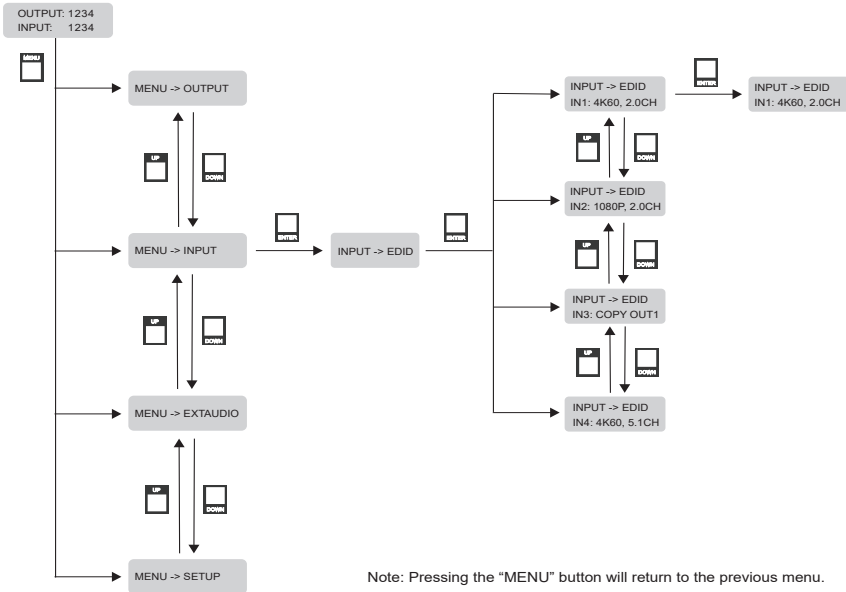

**RS-232 control operation:** Connect the Matrix to PC with a serial cable, then open a Serial Command tool on PC to send ASCII command "s input x EDID z!" to set EDID. For details, please refer to "EDID Setting" in the ASCII command list of "RS-232 Control Command".

# EDID Management

**Web GUI Operation:** Please check the EDID management in the “Input page” of “Web GUI User Guide”.

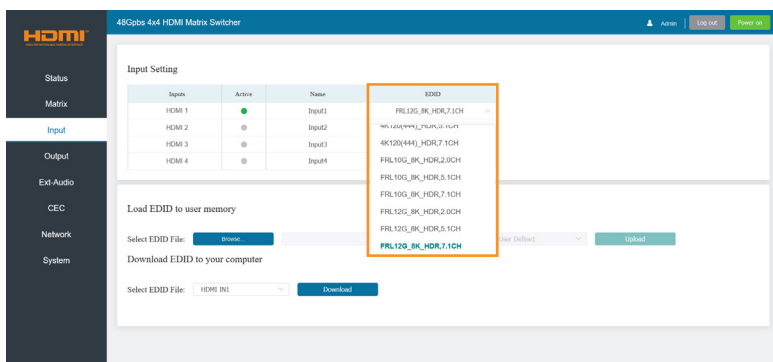

The defined EDID setting list of the product is shown as below:

No.	EDID Mode	No.	EDID Mode	No.	EDID Mode
1	1080P, 2.0CH	16	4K30_HDR, 2.0CH	31	FRL10G_8K_HDR, 2.0CH
2	1080P, 5.1CH	17	4K30_HDR, 5.1CH	32	FRL10G_8K_HDR, 5.1CH
3	1080P, 7.1CH	18	4K30_HDR, 7.1CH	33	FRL10G_8K_HDR, 7.1CH
4	4K30, 2.0CH	19	4K60(420)_HDR, 2.0CH	34	FRL12G_8K_HDR, 2.0CH
5	4K30, 5.1CH	20	4K60(420)_HDR, 5.1CH	35	FRL12G_8K_HDR, 5.1CH
6	4K30, 7.1CH	21	4K60(420)_HDR, 7.1CH	36	FRL12G_8K_HDR, 7.1CH
7	4K60(420), 2.0CH	22	4K60(444)_HDR, 2.0CH	37	user1_EDID
8	4K60(420), 5.1CH	23	4K60(444)_HDR, 5.1CH	38	user2_EDID
9	4K60(420), 7.1CH	24	4K60(444)_HDR, 7.1CH	39	user3_EDID
10	4K60(444), 2.0CH	25	4K120(420)_HDR, 2.0CH	40	copy out1
11	4K60(444), 5.1CH	26	4K120(420)_HDR, 5.1CH	41	copy out2
12	4K60(444), 7.1CH	27	4K120(420)_HDR, 7.1CH	42	copy out3
13	1080P_HDR, 2.0CH	28	4K120(444)_HDR, 2.0CH	43	copy out4
14	1080P_HDR, 5.1CH	29	4K120(444)_HDR, 5.1CH		
15	1080P_HDR, 7.1CH	30	4K120(444)_HDR, 7.1CH		

# Web GUI User Guide

The Matrix can be controlled by Web GUI. The operation method is shown as below:

**Step 1:** Get the current IP Address.

The default IP address is 192.168.0.100. You can get the current Matrix IP address in two ways:

**The first way:** You can get the IP address via panel buttons. On the initial LCD display, press “MENU” button to enter the first level menu. Then press “UP/DOWN” button to select “SETUP”, and press “ENTER” to enter the second level menu. Then press “UP/DOWN” button to select “IP INFO”, and press “ENTER” to check current IP address.

**The second way:** You can get the IP address via RS-232 control. Send the ASCII command “r ipconfig!” through an ASCII Command tool, then you’ll get the feedback information as shown below:

---

```
IP Mode: Static
IP: 192.168.0.100
Subnet Mask: 255.255.255.0
Gateway: 192.168.0.1
TCP/IP port=8000
Telnet port=23
Mac address: 00:1C:91:03:80:01
```

IP:192.168.0.100 in the above figure is the current Matrix IP address (this IP address is variable, depending on what the specific machine returns).

For the details of ASCII control, please refer to “**RS-232 Control Command**”.

**Step 2:** Connect the TCP/IP port of the Matrix to a PC with a UTP ethernet cable, and set the IP address of the PC to be in the same network segment with the Matrix.

**Step 3:** Input the IP address of the Matrix into your browser on the PC to enter Web GUI page. After entering the Web GUI page, there will be a Login page, as shown below:



# Web GUI User Guide



Select the Language from the drop-down list to choose English or Simple Chinese. Select the Username from the drop-down list and enter the password. The default passwords are:

Username **User Admin**

Password **user admin**

After entering the password, click the “LOGIN” button and the following Status page will appear.

## ■ Status Page

The Status page provides basic information about the product model, installed firmware version and the network settings of the device.

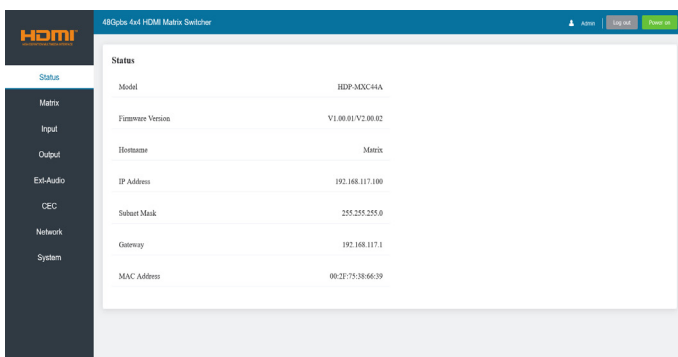

# Web GUI User Guide

## ■ Matrix Page

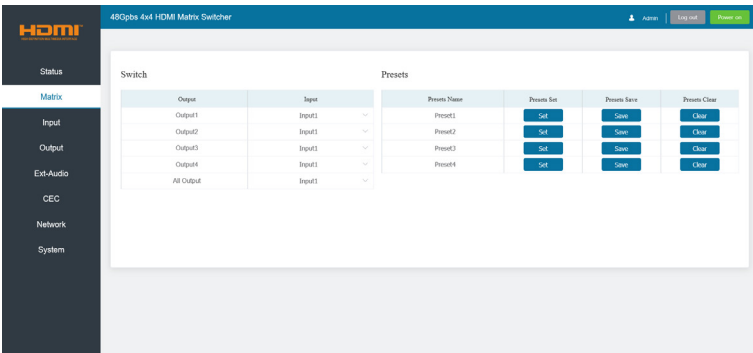

You can do the following operations on the Matrix page:

- ① **Switch:** Select the input signal source to output. The display name of each Input and Output can be modified in Input page and Output page. The Input drop-down list shows all input sources. Click Input drop-down menu and select the input signal source which will be transmitted to the corresponding output.
- ② **Presets:** Set, save and clear the presets. Preset1 matches with the group of Output1 and the assigned Input. Click Set button to set this preset. You can save or clear it via clicking Save or Clear. Each group of the Output and Input can be set, save and clear on the page. 4 presets are allowed to be set.

### All Output:

- The set of All Output is available to all outputs above. You can select an input source for All Output to be used for 1~4 outputs.
- It is null when one or more inputs assigned for outputs are different from others.

## ■ Input Page

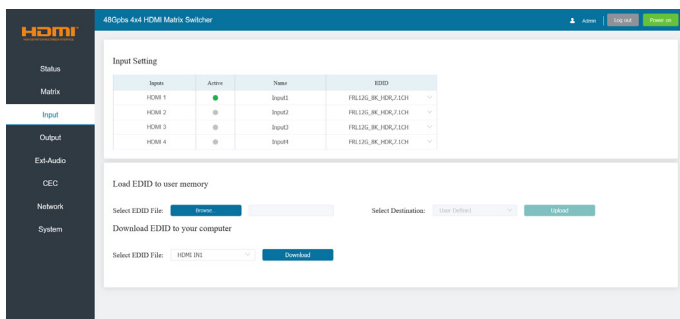

You can do the following operations on the Input page:

- ① **Inputs:** Input channel of the device.
- ② **Active:** It indicates whether the channel is connected to a signal source. It is green if the input signal is detected, and gray if no signal.
- ③ **Name:** The input channel's name. You can modify it by entering the corresponding name (max length: 31 characters for English) in the input box.
- ④ **EDID:** You can set the current channel's EDID. Click drop-down list to select other EDIDs.
- ⑤ **Load EDID to user memory:** Set EDID for the User.

Click the "Browse" button, then select the bin file. If you select the wrong EDID file, there will be a prompt, as shown in the following figure:

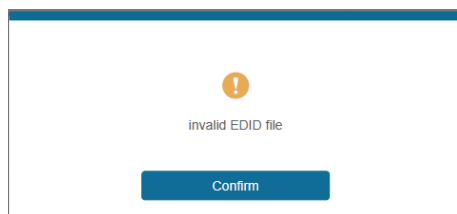

# Web GUI User Guide

Make sure to select the correct file, then you can check the name of the selected file. Then select destination “User Define1/User Define2/User Define3”, and click “Upload”.

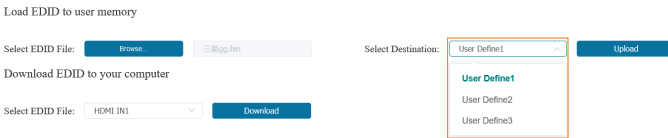

After successful setting, it will prompt as follows:

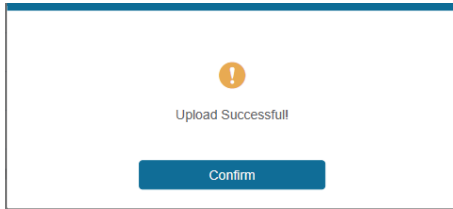

## ⑥ Download EDID to your computer:

If you want to download the existing EDID, click the drop-down box of “Select EDID File” to select the input channel you want, and then click “Download” to save the corresponding EDID file to your computer.

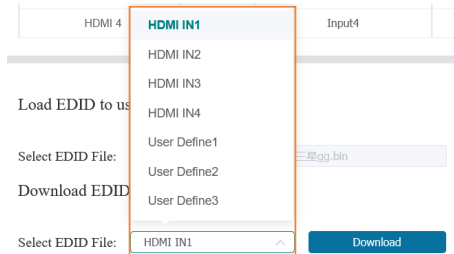

# Web GUI User Guide

## ■ Output Page

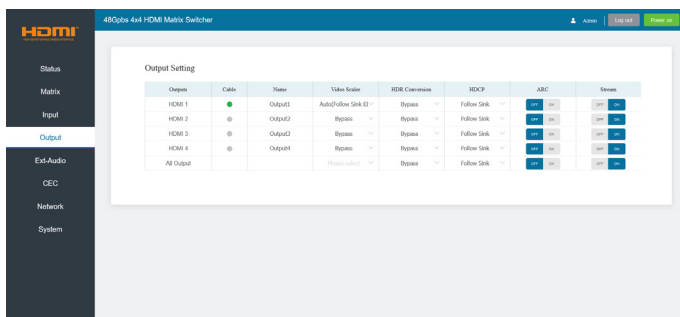

You can do the following operations on the Output page:

① **Outputs:** Output channel of the device.

### All Output:

- The set of All Output is available to all outputs above if you select a value from the drop-down list.
- It is null when one or more selections for outputs above are different from others.

② **Cable:** It indicates the connection status of output ports. When the output port is connected to the display, it shows green, otherwise, it shows gray.

③ **Name:** The output channel's name. You can modify it by entering the corresponding name (max length: 31 characters) in the input box.

④ **Video Scaler:** This product support video downscaling on all outputs. It will output the proper video resolution according to the EDID of the display device. Click the drop-down menu and set the video scaler mode you need.

Output Setting

Outputs	Cable	Name	Video Scaler	HDR Conversion	HDCP	ARC	Stream
HDMI 1	●	Output1	(Follow Sink EDID) ~	Bypass	Follow Sink	OFF ON	OFF ON
HDMI 2	●	Output2	Bypass	Bypass	Follow Sink	OFF ON	OFF ON
HDMI 3	●	Output3	Bypass	Bypass	Follow Sink	OFF ON	OFF ON
HDMI 4	●	Output4	Bypass	Bypass	Follow Sink	OFF ON	OFF ON
All Output			Bypass	Bypass	Follow Sink	OFF ON	OFF ON

# Web GUI User Guide

There are four options to be selected:

- **Bypass (Default):** It means the output resolution follows the input source.
- **8K -> 4K:** Downscapes any 8K signal to 4K.
- **8K/4K -> 1080P:** Downscapes any 8K/4K signal to 1080p.
- **Auto (Follow Sink EDID):** It means the output resolution is according to the EDID of the corresponding display device.

The example of video scaler is shown as below.

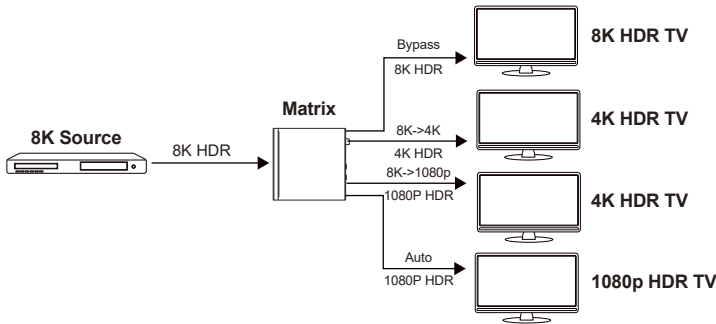

⑤ **HDR Conversion:** This product supports HDR to SDR convert on all outputs. It will output the proper HDMI signal according to the EDID of the display device. Click the drop-down menu and set the video HDR conversion mode you need.

Output Setting

Outputs	Cable	Name	Video Scaler	HDR Conversion	HDCP	ARC	Stream
HDMI 1	●	Output1	{Follow Sink EDID}	Bypass	Follow Sink	OFF ON	OFF ON
HDMI 2	●	Output2	Bypass	Bypass	Follow Sink	OFF ON	OFF ON
HDMI 3	●	Output3	Bypass	Bypass	Follow Sink	OFF ON	OFF ON
HDMI 4	●	Output4	Bypass	Bypass	Follow Sink	OFF ON	OFF ON
All Output			Please select	Bypass	Follow Sink	OFF ON	OFF ON

# Web GUI User Guide

There are three options to be selected:

- **Bypass (Default):** It means the output format follows the input source.
- **HDR to SDR:** Converts HDMI signals from HDR to SDR to meet the needs of output.
- **Auto (Follow Sink EDID):** It means the output format is according to the EDID of the corresponding display device.

The example of video scaler is shown as below.

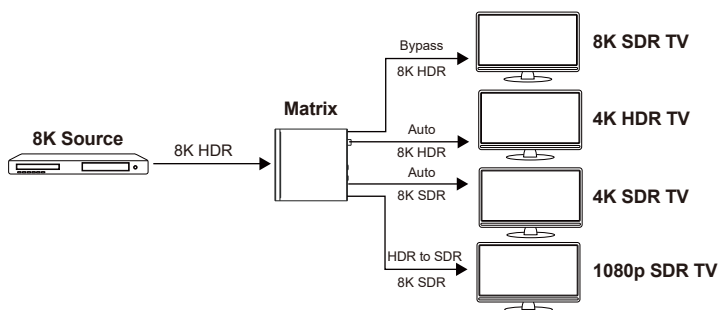

## ⑥ HDCP: Set the HDCP version that the current output port supports.

Output Setting

Outputs	Cable	Name	Video Scaler	HDR Conversion	HDCP	ARC	Stream
HDMI 1	<input checked="" type="radio"/>	Output1	(Follow Sink EDID)	Bypass	Follow Sink	<input type="checkbox"/> OFF <input checked="" type="checkbox"/> ON	<input type="checkbox"/> OFF <input checked="" type="checkbox"/> ON
HDMI 2	<input type="radio"/>	Output2	Bypass	Bypass	HDCP 1.4	<input type="checkbox"/> OFF <input checked="" type="checkbox"/> ON	<input type="checkbox"/> OFF <input checked="" type="checkbox"/> ON
HDMI 3	<input type="radio"/>	Output3	Bypass	Bypass	HDCP 2.2	<input type="checkbox"/> OFF <input checked="" type="checkbox"/> ON	<input type="checkbox"/> OFF <input checked="" type="checkbox"/> ON
HDMI 4	<input type="radio"/>	Output4	Bypass	Bypass	Follow Sink	<input type="checkbox"/> OFF <input checked="" type="checkbox"/> ON	<input type="checkbox"/> OFF <input checked="" type="checkbox"/> ON
All Output			Please select	Bypass	Follow Source	<input type="checkbox"/> OFF <input checked="" type="checkbox"/> ON	<input type="checkbox"/> OFF <input checked="" type="checkbox"/> ON
					USER MODE		

There are five options to be selected:

- **HDCP 1.4:** HDCP 1.4 compliant.
- **HDCP 2.2:** HDCP 2.2 compliant.
- **Follow Sink:** HDCP version follows the corresponding display device.
- **Follow Source:** HDCP version follows the assigned input source.
- **USER MODE:** Supports user-defined mode.

# Web GUI User Guide

⑦ **ARC:** Click ON/OFF button to enable/disable the ARC function of the display device.

⑧ **Stream:** Click ON/OFF button to turn on/off the output stream.

## ■ Ext-Audio Page

You can set the audio mode on the Ext-Audio page. There are three modes: Bind to Input, Bind to Output and Audio Matrix.

**Bind to Input:** The audio output follows the HDMI input. And there is a consistent one-to-one match between each HDMI input and audio output.

Click Enable/Disable button to turn on/off the audio channel.

In this mode, the input sources and output ARC can't be selected.

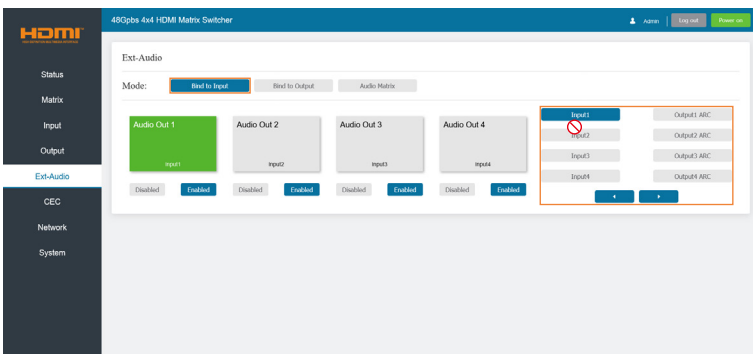

**Bind to Output:** The audio output follows the HDMI output. For example, if the HDMI input 3 is assigned to the HDMI output 1, the audio of AUDIO OUT 1 which follows HDMI output 1 is from HDMI input 3.

Click Enable/Disable button to turn on/off the audio channel.

In this mode, the input sources and output ARC can't be selected.



# Web GUI User Guide

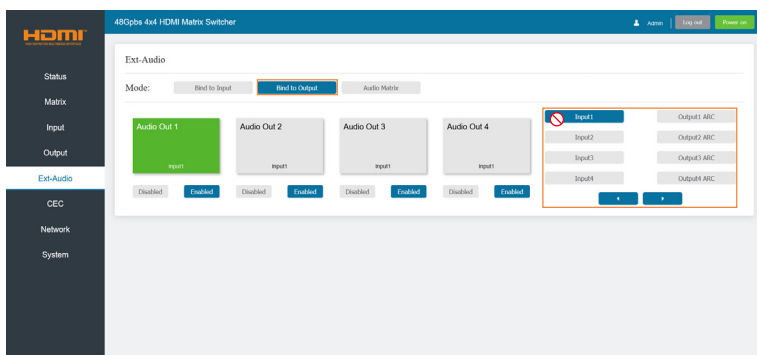

**Audio Matrix:** This mode allows you to matrix the extracted audio independently. Click on an Audio Out, and then select any input source or ARC audio on the right which will appear below the selected audio out. One route of audio configuration is completed.

Click Enable/Disable button to turn on/off the corresponding audio channel.

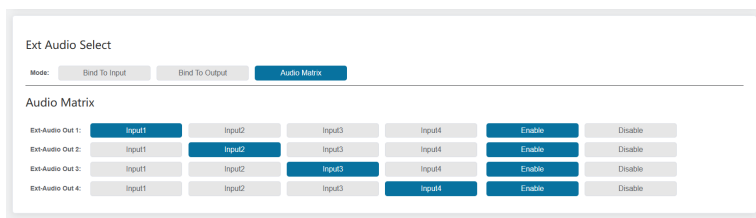

## ■ CEC Page

You can perform CEC management on this page. Inputs and Outputs can be controlled by clicking on the corresponding icons.

# Web GUI User Guide

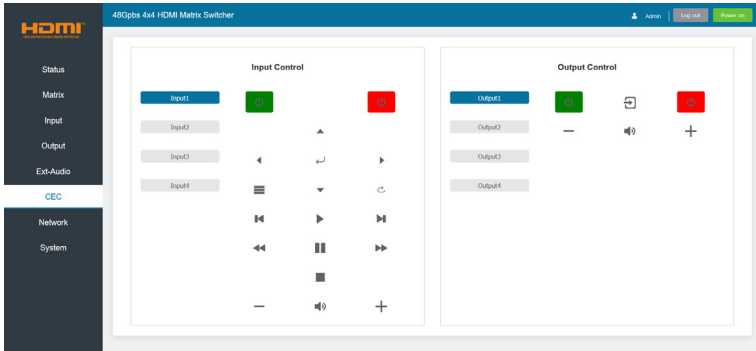

① **Input Control:** Select the input source on the left, and then click on the icons to power on, power off, return, switch, pause, fast-forward, fast-back, mute, unmute, etc.

② **Output Control:** Select the output on the left, and then click on the icons to power on/off, volume +/-, etc.

## ■ Network Page

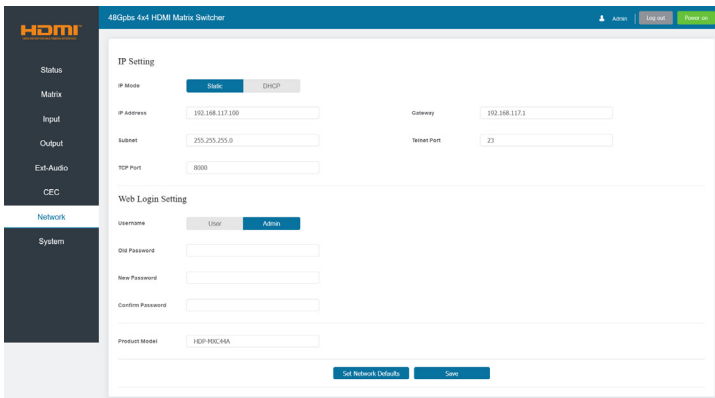

# Web GUI User Guide

You can do the following operations on the Network page:

## ① **Modify Network Setting:**

Modify the IP Mode/IP Address/Gateway/Subnet Mask/Telnet Port as required, click “Save” to save the settings, and then it will come into effect.

The screenshot shows the 'IP Setting' configuration page. At the top, there are two radio buttons for 'IP Mode': 'Static' (which is selected and highlighted in blue) and 'DHCP'. Below this, there are four input fields: 'IP Address' (192.168.117.100), 'Gateway' (192.168.117.1), 'Subnet' (255.255.255.0), and 'Telnet Port' (23). At the bottom, there is a 'TCP Port' input field with the value 8000. A red rectangular box highlights the IP Address, Gateway, Subnet, and Telnet Port fields.

If the Mode is “Static”, you can set manually the IP Address/Gateway/Subnet/Telnet Port as required.

The screenshot shows the 'IP Setting' configuration page. At the top, there are two radio buttons for 'IP Mode': 'Static' and 'DHCP' (which is selected and highlighted in blue). Below this, there are four input fields: 'IP Address' (192.168.0.100), 'Gateway' (192.168.0.1), 'Subnet' (255.255.0.0), and 'Telnet Port' (23). At the bottom, there is a 'TCP Port' input field with the value 8000. A red rectangular box highlights the IP Address, Gateway, Subnet, and Telnet Port fields.

If the Mode is “DHCP”, it will search and be filled with the IP Address assigned by the router automatically. You can't modify it now.

## ② **Modify User Password:**

Click the “User” button, enter the correct Old Password, New Password, and Confirm Password, and then click “Save”. After successful modification, there will be a prompt, as shown in the following figure:

### Web Login Setting

The screenshot shows the 'Web Login Setting' configuration page. At the top, there are two radio buttons for 'Username': 'User' (which is selected and highlighted in blue) and 'Admin'. Below this, there are four input fields: 'Old Password', 'New Password', and 'Confirm Password'. A red rectangular box highlights the Old Password, New Password, and Confirm Password fields.

The screenshot shows a confirmation message box. At the top, there is a yellow warning icon. Below it, the text reads 'modify successfully!'. At the bottom, there is a blue button labeled 'Confirm'.

# Web GUI User Guide

**Note:** Input rules for changing passwords:

- (1) The password can't be empty.
- (2) New Password can't be the same as Old Password.
- (3) New Password and Confirm Password must be the same.

### ③ Set the Default Network:

Click "Set Network Defaults", there will be a prompt, as shown in the following figure:

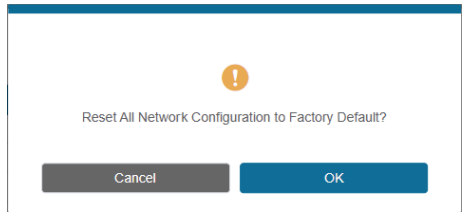

Click "OK" to search the IP Address again. After searching is completed, it will switch to the login page, the default network setting is completed.

## ■ System Page

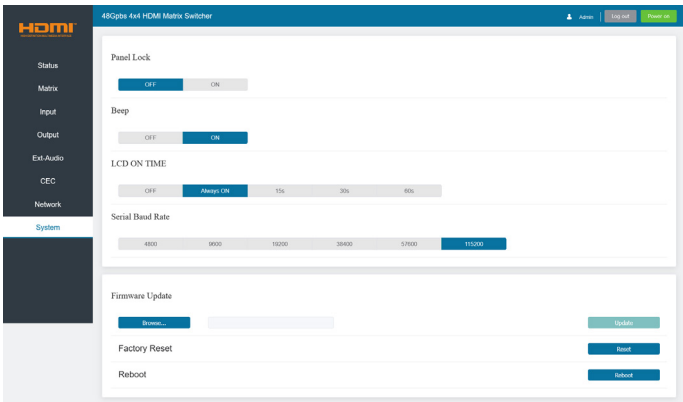

# Web GUI User Guide

You can do the following operations on the System page:

- ① **Panel Lock:** Click "ON/OFF" to lock/unlock panel buttons. "ON" indicates that panel buttons are unavailable; "OFF" indicates panel buttons are available.
- ② **Beep:** Turn on/off the beep.
- ③ **LCD On Time:** You can turn on/off the LCD, and set the display duration time (Always ON/15s/30s/60s).
- ④ **Serial Baud Rate:** Click the value to set the Serial Baud Rate.
- ⑤ **Firmware Update:** Click "Browse" to select the update file, and then click "Update" to complete firmware update.
- ⑥ **Factory Reset:** Reset the unit to factory defaults by clicking "Reset".
- ⑦ **Reboot:** Reboot the unit by clicking "Reboot".

**Note:** After reset/reboot, it will switch to the login page.

# RS-232 Control Command

The product also supports RS-232 control. You need a serial cable with RS-232 male head and DB9 transfer USB male head. The RS-232 head of the serial cable is connected to the RS-232 control port with DB9 at the rear of the Matrix, and the USB head of the serial cable is connected to a PC. The connection method is as follows:

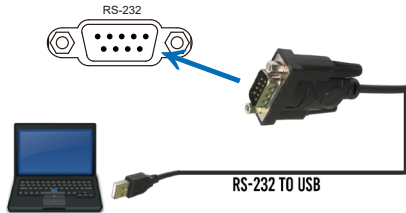

Then open a Serial Command tool on PC to send ASCII commands to control the device. The ASCII command list of the product is as below.

ASCII Commands				
Serial port protocol. Baud rate: 115200, Data bits: 8bit, Stop bits:1, Check bit: 0				
TCP/IP protocol port: 8000      Telnet port: 23				
x,y,z, XXX are parameters      Error Code describe: E00 -> unknown command, E01 -> parameter out of range, E02 -> get the error edid data				
Command Code	Function Description	Example	Feedback	Default
<b>System Setting</b>				
help!	List all commands	help!		
status!	Get device current status	status!	Get the unit all status: power, beep, lock, in/out connection, video/audio crosspoint, edid, network status	
r type!	Get device model	r type!	4x4 HDMI2.1 Matrix	
r fw version!	Get Firmware version	r fw version!	MCU FW version x.xx.xx	
power z!	Power on/off the device, z=0~1 (z=0 power off, z=1 power on)	power 1!	power on System Initializing... Initialization Finished! MCU FW version x.xx.xx	

# RS-232 Control Command

Command Code	Function Description	Example	Feedback	Default
<b>System Setting</b>				
r power!	Get current power state	r power!	power on /power off	
s beep z!	Enable/Disable buzzer function, z=0-1 (z=0 beep off, z=1 beep on)	s beep 1!	beep on beep off	beep off
r beep!	Get buzzer state	r beep!	beep on / beep off	
s lock z!	Lock/Unlock front panel button, z=0-1 (z=0 lock off, z=1 lock on)	s lock 1!	panel button lock on panel button lock off	panel button lock off
r lock!	Get panel button lock state	r lock!	panel button lock on/ off	
s lcd on time z!	Set LCD screen remain on time, z=0~4 (0:off 1:always, 2:15s, 3:30s, 4:60s)	s lcd on time 3!	lcd on 30 seconds	lcd on 30 seconds
r lcd mode!	Get the backlight status of lcd screen	r lcd mode!	lcd always on	
s logo1 *****!	Set the logo name displayed on the first line of LCD screen, the max character is 16	s logo1 Matrix Switch!	logo1:Matrix Switch	
reboot!	Reboot the device	reboot!	Reboot... 4x4 hdmi 2.1 matrix system initializing... initialization finished! mcu fw version : vx.xx.xx	
reset!	Reset to factory defaults	reset!	Reset to factory defaults 4x4 hdmi2.1 matrix system initializing... initialization finished! mcu fw version : vx.xx.xx	
r link in x!	Get the connection status of the x input port, x=0-4 (0=all)	r link in 1!	hdmi input 1: connect/ sync/disconnect	
r link out y!	Get the connection status of the y output port, y=0-4 (0=all)	r link out 1!	hdmi output 1: connect/disconnect	

# RS-232

## Control Command

Command Code	Function Description	Example	Feedback	Default
<b>System Setting</b>				
s save preset z!	Save switch state between all output port and the input port to preset z, z=1~4	s save preset 1!	save to preset 1	
s recall preset z!	Call saved preset z scenarios, z=1~4	s recall preset 1!	recall from preset 1	
s clear preset z!	Clear stored preset z scenarios, z=1~4	s clear preset 1!	clear preset 1	
r preset z!	Get preset z information, z=1~4	r preset 1!	video/audio crosspoint	
<b>Output Setting</b>				
s output y in source x!	Route input x source to output y (y=0~4, 0=all, x=1~4) x=1. input 1, x=2. input 2 x=3. input 3, x=4. input 4	s output 1 in source 1!	output1->input1	output1->input1 output2->input2 output3->input3 output4->input4
r output y in source!	Get output y selected input source (y=0~4, 0=all)	r output 1 in source!	output1->input1	
s output y hdcp x!	Set output hdcp (y=0~4, x=1~5) x=1. HDCP 1.4 x=2. HDCP 2.2 x=3. Follow sink x=4. Follow source x=5. USER MODE	s output 1 hdcp 2!	output 1 HDCP: HDCP 2.2	Follow sink
r output y hdcp!	Get output y hdcp status. (y=0~4, 0=all)	r output 1 hdcp!	output 1 HDCP: HDCP 2.2	
s output y stream x!	Set output y stream enable/disable (y=0~4, 0=all, x=0~1) x=0. stream disable x=1. stream enable	s output 1 stream 1!	output 1 stream: Enable	Enable
r output y stream!	Get output y stream status. (y=0~4, 0=all)	r output 1 stream!	output 1 stream: Enable	



Command Code	Function Description	Example	Feedback	Default
<b>Output Setting</b>				
s output y scaler x!	Set output y port scaler mode (y=0-4, 0=all, x=1-4) x=1. pass-through x=2. 8k->4k x=3. 8k/4k->1080p x=4. auto (follow sink EDID)	s output 1 scaler 2!	output 1 scaler mode: 8k->4k	pass-through
r output y scaler!	Get output y port scaler mode y=0-4 (0=all)	r output 1 scaler!	output 1 scaler mode: 8k->4k	
s output y hdr x!	Set output y port HDR to SDR mode (y=0-4, 0=all, x=1-3) x=1. pass-through x=2. HDR to SDR x=3. auto (follow sink EDID)	s output 1 hdr 2!	output 1 HDR mode: HDR to SDR	pass-through
r output y hdr!	Get output y port HDR to SDR mode y=0-4 (0=all)	r output 1 hdr!	output 1 HDR mode: HDR to SDR	
s output y arc x!	Set output y ARC on/off (y=0-4, 0=all, x=0-1) x=0. off x=1. on	s output 1 arc 0!	output 1 arc: off	off
r output y arc!	Get output y ARC status y=0-4 (0=all)	r output 1 arc!	output 1 arc: off	
<b>EDID Setting</b>				
s input x edid copy output y!	Set HDMI input x EDID copy from output y (x=0-4, 0=all, y=1-4)	s input 1 edid copy output 1!	input 1 EDID: copy from output 1	
r input x EDID!	Get input x EDID mode (x=0-4, 0=all)	r input 1 EDID!	FRL12G_8K_HDR,7.1CH	
s user x edid 00 FF FF ...!	Set user x EDID data (x=1-3) x=1. user1_EDID x=2. user2_EDID x=3. user3_EDID	s user 1 edid 00 FF FF FF FF ...!	user 1 EDID data: 00 FF FF FF FF FF FF 00 .....	
r user x edid!	Get user x EDID data (x=1-3)	r user 1 edid!	user 1 EDID data: 00 FF FF FF FF FF FF 00 .....	

# RS-232

## Control Command

Command Code	Function Description	Example	Feedback	Default
<b>EDID Setting</b>				
s input x EDID z!	Set HDMI input x EDID mode (x=0~4, z=1~39) z=1. 1080P,2.0CH, z=2. 1080P,5.1CH, z=3. 1080P,7.1CH z=4. 4K30,2.0CH, z=5. 4K30,5.1CH, z=6. 4K30,7.1CH z=7. 4K60(420),2.0CH, z=8. 4K60(420),5.1CH, z=9. 4K60(420),7.1CH z=10. 4K60(444),2.0CH, z=11. 4K60(444),5.1CH, z=12. 4K60(444),7.1CH z=13. 1080P_HDR,2.0CH, z=14. 1080P_HDR,5.1CH, z=15. 1080P_HDR,7.1CH z=16. 4K30_HDR,2.0CH, z=17. 4K30_HDR,5.1CH, z=18. 4K30_HDR,7.1CH z=19. 4K60(420)_HDR,2.0CH, z=20. 4K60(420)_HDR,5.1CH, z=21. 4K60(420)_HDR,7.1CH z=22. 4K60(444)_HDR,2.0CH, z=23. 4K60(444)_HDR,5.1CH, z=24. 4K60(444)_HDR,7.1CH z=25. 4K120(420)_HDR,2.0CH, z=26. 4K120(420)_HDR,5.1CH, z=27. 4K120(420)_HDR,7.1CH z=28. 4K120(444)_HDR,2.0CH, z=29. 4K120(444)_HDR,5.1CH, z=30. 4K120(444)_HDR,7.1CH z=31. FRL10G_8K_HDR,2.0CH, z=32. FRL10G_8K_HDR,5.1CH, z=33. FRL10G_8K_HDR,7.1CH z=34. FRL12G_8K_HDR,2.0CH, z=35. FRL12G_8K_HDR,5.1CH, z=36. FRL12G_8K_HDR,7.1CH, z=37. user1_EDID, z=38. user2_EDID, z=39. user3_EDID	s input 1 EDID 36!	input 1 EDID: FRL12G_8K_ HDR,7.1CH	FRL12G_ 8K_HDR, 7.1CH

Command Code	Function Description	Example	Feedback	Default
<b>Ext-audio Setting</b>				
s output y exa x!	Set output y ext-audio enable/disable (y=0-4, 0=all, x=0-1) x=0. ext-audio disable x=1. ext-audio enable	s output 1 exa 1!	output 1 ext-audio: Enable	Enable
r output y exa!	Get output y ext-audio enable/disable status (y=0-4, 0=all)	r output 1 exa!	output 1 ext-audio: Enable	
s output exa mode x!	Set output ext-audio mode (x=0-2) x=0. bind to input mode x=1. bind to output mode x=2. matrix mode	s output exa mode 0!	output ext-audio mode: bind to input	bind to input
r output exa mode!	Get output ext-audio mode	r output exa mode!	output ext-audio mode: bind to input	
s output y exa in source x!	Route input source audio to output ext-audio y (y=0-4, x=1-8) x=1. input 1, x=2. input 2, x=3. input 3, x=4. input 4, x=5. output 1 ARC, x=6. output 2 ARC, x=7. output 3 ARC, x=8. output 4 ARC.	s output 1 exa in source 1!	output1 ext-audio ->input1	output1 ext-audio->input1 output2 ext-audio->input2 output3 ext-audio->input3 output4 ext-audio->input4
r output y exa in source!	Get output y ext-audio selected input source (y=0-4, 0=all)	r output 0 exa in source!	output1 ext-audio->input1 output2 ext-audio->input2 output3 ext-audio->output3 ARC output4 ext-audio->output4 ARC	

# RS-232

## Control Command

Command Code	Function Description	Example	Feedback	Default
<b>CEC Setting</b>				
s cec in x on!	Set input x power on by CEC, x=0-4 (0=all input)	s cec in 1 on!	input 1 power on	
s cec in x off!	Set input x power off by CEC, x=0-4 (0=all input)	s cec in 1 off!	input 1 power off	
s cec in x menu!	Set input x open menu by CEC, x=0-4 (0=all input)	s cec in 1 menu!	input 1 open menu	
s cec in x back!	Set input x back operation by CEC, x=0-4 (0=all input)	s cec in 1 back!	input 1 back operation	
s cec in x up!	Set input x menu up operation by CEC, x=0-4 (0=all input)	s cec in 1 up!	input 1 menu up operation	
s cec in x down!	Set input x menu down operation by CEC, x=0-4 (0=all input)	s cec in 1 down!	input 1 menu down operation	
s cec in x left!	Set input x menu left operation by CEC, x=0-4 (0=all input)	s cec in 1 left!	input 1 menu left operation	
s cec in x right!	Set input x menu right operation by CEC, x=0-4 (0=all input)	s cec in 1 right!	input 1 menu right operation	
s cec in x enter!	Set input x menu enter by CEC, x=0-4 (0=all input)	s cec in 1 enter!	input 1 menu enter operation	
s cec in x play!	Set input x play by CEC, x=0-4 (0=all input)	s cec in 1 play!	input 1 play operation	
s cec in x pause!	Set input x pause by CEC, x=0-4 (0=all input)	s cec in 1 pause!	input 1 pause operation	
s cec in x stop!	Set input x stop by CEC, x=0-4 (0=all input)	s cec in 1 stop!	input 1 stop operation	
s cec in x rew!	Set input x rewind by CEC, x=0-4 (0=all input)	s cec in 1 rew!	input 1 rewind operation	
s cec in x mute!	Set input x volume mute by CEC, x=0-4 (0=all input)	s cec in 1 mute!	input 1 volume mute	

Command Code	Function Description	Example	Feedback	Default
<b>CEC Setting</b>				
s cec in x vol-!	Set input x volume down by CEC, x=0~4 (0=all input)	s cec in 1 vol-!	input 1 volume down	
s cec in x vol+!	Set input x volume up by CEC, x=0~4 (0=all input)	s cec in 1 vol+!	input 1 volume up	
s cec in x ff!	Set input x fast forward by CEC, x=0~4 (0=all input)	s cec in 1 ff!	input 1 fast forward operation	
s cec in x previous!	Set input x previous by CEC, x=0~4 (0=all input)	s cec in 1 previous!	input 1 previous operation	
s cec in x next!	Set input x next by CEC, x=0~4 (0=all input)	s cec in 1 next!	input 1 next operation	
s cec hdmi out y on!	Set hdmi output y power on by CEC, y=0~4 (0=all hdmi output)	s cec hdmi out 1 on!	hdmi output 1 power on	
s cec hdmi out y off!	Set hdmi output y power off by CEC, y=0~4 (0=all hdmi output)	s cec hdmi out 1 off!	hdmi output 1 power off	
s cec hdmi out y mute!	Set hdmi output y volume mute by CEC, y=0~4 (0=all hdmi output)	s cec hdmi out 1 mute!	hdmi output 1 volume mute	
s cec hdmi out y vol-!	Set hdmi output y volume down by CEC, y=0~4 (0=all hdmi output)	s cec hdmi out 1 vol-!	hdmi output 1 volume down	
s cec hdmi out y vol+!	Set hdmi output y volume up by CEC, y=0~4 (0=all hdmi output)	s cec hdmi out 1 vol+!	hdmi output 1 volume up	
s cec hdmi out y active!	Set hdmi output y active source by CEC, y=0~4 (0=all hdmi output)	s cec hdmi out 1 active!	hdmi output 1 active source	
<b>Network Setting</b>				
r ipconfig!	Get the Current IP Configuration	r ipconfig !	IP Mode: Static IP: 192.168.0.100 Subnet Mask: 255.255.255.0 Gateway: 192.168.0.1 TCP/IP port:8000 Telnet port:23 Mac address: 00:1C:91:03:80:01	

# RS-232

## Control Command

Command Code	Function Description	Example	Feedback	Default
<b>Network Setting</b>				
r mac addr!	Get network MAC address	r mac addr!	Mac address: 00:1C:91:03:80:01	
s ip mode z!	Set network IP mode to static IP or DHCP, z=0-1 (z=0 Static, z=1 DHCP)	s ip mode 0!	Set IP mode:Static. (Please use "s net reboot!" command to apply new config!)	
r ip mode!	Get network IP mode	r ip mode!	IP mode: Static	
s ip addr xxx.xxx.xxx!	Set network IP address	s ip addr 192.168.0.100!	Set IP address:192.168.0.100 (Please use "s net reboot!" command to apply new config!) DHCP on, Device can't config static address, set DHCP off first.	
r ip addr!	Get network IP address	r ip addr!	IP address:192.168.0.100	
s subnet xxx.xxx.xxx!	Set network subnet mask	s subnet 255.255.255.0!	Set subnet mask:255.255.255.0 (Please use "s net reboot!" command to apply new config!) DHCP on, Device can't config subnet mask, set DHCP off first.	
r subnet!	Get network subnet mask	r subnet!	Subnet Mask:255.255.255.0	
s gateway xxx.xxx.xxx!	Set network gateway	s gateway 192.168.0.1!	Set gateway:192.168.0.1 (Please use "s net reboot!" command to apply new config!) DHCP on, Device can't config gateway, set DHCP off first.	
r gateway!	Get network gateway	r gateway!	Gateway:192.168.0.1	
s tcp/ip port x!	Set network TCP/IP port (x=1~65535)	s tcp/ip port 8000!	Set TCP/IP port:8000	

# RS-232 Control Command

Command Code	Function Description	Example	Feedback	Default
<b>Network Setting</b>				
r tcp/ip port!	Get network TCP/IP port	r tcp/ip port!	TCP/IP port:8000	
s telnet port x!	Set network telnet port (x=1~65535)	s telnet port 23!	Set Telnet port:23	
r telnet port!	Get network telnet port	r telnet port!	Telnet port:23	
s net reboot!	Reboot network modules	s network reboot!	Network reboot... IP Mode: Static IP: 192.168.0.100 Subnet Mask: 255.255.255.0 Gateway: 192.168.0.1 TCP/IP port=8000 Telnet port=23 Mac address: 00:1C:91:03:80:01	

# Application Example

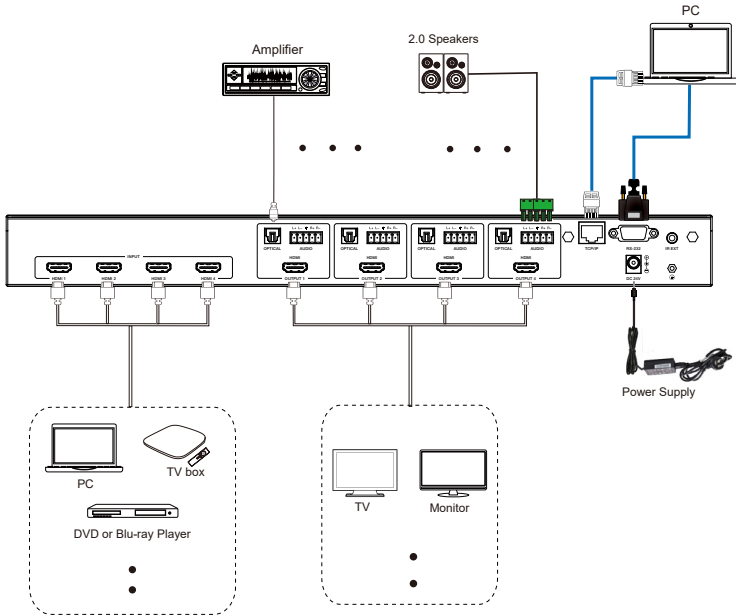

## Steps To Connect:

1. Connect the media devices such as the Apple TV, FireTV Stick, etc. to the HDMI Input ports on the Matrix.
2. Connect your display devices such as a TV, Monitor, etc. to the HDMI Output ports on the Matrix.
3. Turn on all the devices and you should get an image on all the displays.
4. Use the IR Remote or the Front Panel buttons to select which input source goes to which output.
5. If needed, you may also connect an audio device to the Optical or Analog ports for audio extraction.
6. Connect a PC or Laptop to the RS-232 or TCP/IP port to control the device through the WebGUI or RS-232 commands.





**8K 48Gbps 4x4  
HDMI Matrix**

**BK-404**

[www.orei.com](http://www.orei.com)

© 2024